

General Specifications

GS 34M6H11-01E

FA-M3

Analog Input/output Modules
Temperature Control and Monitoring Modules
PID Control Module

FA-M3

Contents

F3AD04-0N Analog Input Module	3
F3AD08-1N Analog Input Module	5
F3DA02-0N Analog Output Module	7
F3DA04-1N Analog Output Module	9
F3DA08-5N Analog Output Module	11
F3CT04-0N and F3CT04-1N Temperature Control and Monitoring Modules (Thermocouple and mV Inputs)	13
F3CR04-0N and F3CR04-1N Temperature Control and Monitoring Modules (RTD mV Input)	19
F3CV04-1N PID Control Module (DC V Input)	25

General Specifications

F3AD04-0N Analog Input Module

FA-M3



General

The F3AD04-0N is an analog-to-digital conversion input module for the FA-M3.

- The input signal range can be selected from 0 V to 5 V DC, 1 V to 5 V DC, and -10 V to 10 V DC.
- A single module can accommodate four input points.
- Four input points can be multiplexed during scanning.
- The input terminals are isolated from the internal circuit by photocouplers.
- The conversion speed is as fast as 1 ms/point.
- Advanced and easy-to-use features such as scaling and filtering are provided.

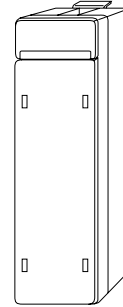

Specifications

Item	Specification
Number of inputs	4
Absolute maximum rating	Max.: 18 V DC Min.: -18 V DC
Input signal range*1	0 V to 5 V DC (-0.25 V to 5.25 V DC) 1 V to 5 V DC (-0.25 V to 5.25 V DC) -10 V to 10 V DC (-11.0 V to 11.0 V DC)
Insulation method	Between input terminals and internal circuit: Photocoupler insulation Between input terminals: Non-insulation minus common
Withstand voltage	500 V DC for 1 minute
Input resistance	1 MΩ
Resolution (12-bit A/D)	0 V to 5 V and 1 V to 5 V DC : 1.4 mV -10 V to 10 V DC : 5.7 mV
Overall accuracy	23 ±2°C: ±0.2% (full scale) 0-5°C: ±0.5% (full scale)
Conversion speed	1 ms × (number of inputs)
Scaling	Upper and lower limit values can be set to any value between -20,000 to 20,000.
Filter	Channels can be enabled or disabled individually.*2
Current consumption	210 mA (5 V DC)
External connection	10-point terminal block, M3.5 screw
External dimensions	28.9 (W) × 100 (H) × 83.2 (D) mm*3
Weight	170 g

*1: Selectable for each channel using software. The default setting is -10 V to 10 V DC.

*2: The actual time constant value varies according to the number of unskipped channels and other settings.

*3: Excluding protrusions (see external dimensions for details).

Components and Functions

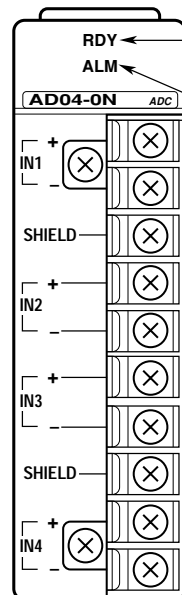

RDY indicator
Lit when the internal circuit is functioning normally.

ALM indicator
Lit when calibration data* is lost. In such a case, the F3AD04-0N will carry out A/D conversion but not satisfy the accuracy requirements.

Terminal block
10-point detachable terminal block. The terminal screws are M3.5 screws with square captive washers.

*: Calibration data is stored in the module to achieve the intended accuracy. The user cannot change this data.

Internal Circuit Diagram

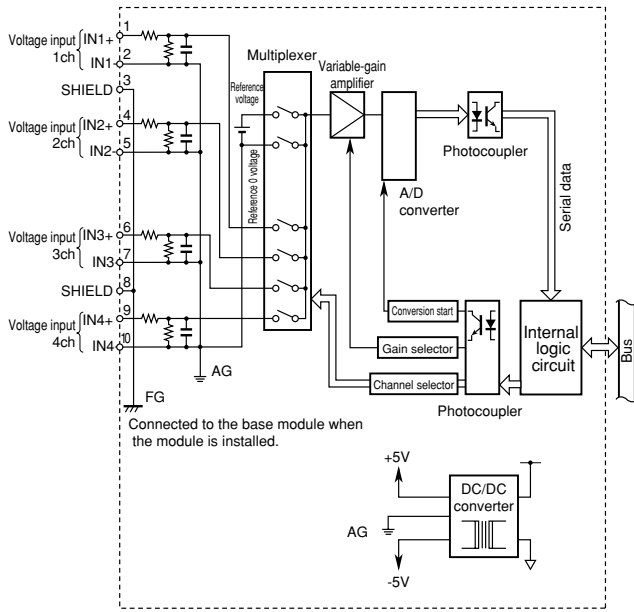

External Connection Diagram

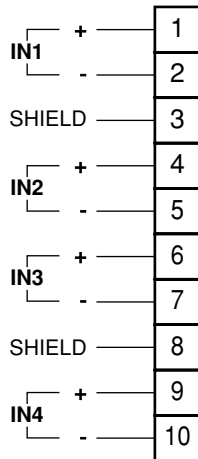

- Shielded terminal 3 is shared by IN1 and IN2.
Shielded terminal 8 is shared by IN3 and IN4.
Shielded terminals are connected to the frame ground of the power supply module via the base module.

Operating Environment

There is no restriction on the type of CPU modules that can be used with this module.

Model and Suffix Codes

Model	Suffix Code	Style Code	Option Code	Description
F3AD04	-0N	0 V to 5 V, 1 V to 5 V, or -10 V to 10 V DC, 4 inputs, 12-bit A/D

External Dimensions

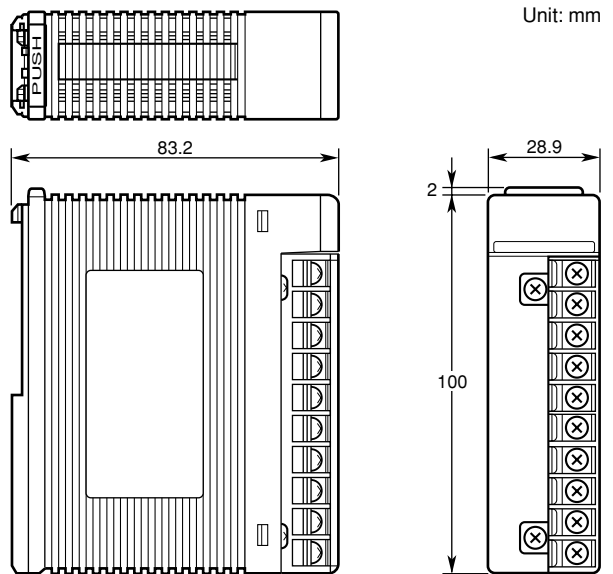

General Specifications

F3AD08-1N Analog Input Module

FA-M3



General

The F3AD08-1N is an analog-to-digital conversion input module for the FA-M3.

- The input signal range can be selected from 0 V to 5 V DC, 1 V to 5 V DC, and -10 V to 10 V DC.
- A single module can accommodate eight input points.
- Eight input points can be multiplexed during scanning.
- The input terminals are isolated from the internal circuit by photocouplers.
- The conversion speed is as fast as 1 ms/point.
- Advanced and easy-to-use features such as scaling and filtering are provided.

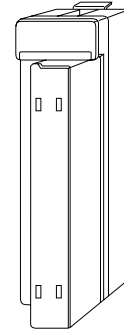

Specifications

Item	Specification
Number of inputs	8 (differential signal input)
Absolute maximum rating	Max.: 18 V DC Min.: -18 V DC
Input signal range*1	0 V to 5 V DC (-0.25 V to 5.25 V DC) 1 V to 5 V DC (-0.25 V to 5.25 V DC) -10 V to 10 V DC (-11.0 V to 11.0 V DC)
Allowable common-mode voltage	±6 V DC max. (0 V to 5 V/1 V to 5 V DC) ±1 V DC max. (-10 V to 10 V DC)
Insulation method	Between input terminals and internal circuit: Photocoupler insulation Between input terminals: Non-insulation
Dielectric strength	500 V DC for 1 minute
Input resistance	1 MΩ or more*2
Resolution (12-bit A/D)	0 V to 5 V and 1 V to 5 V DC :1.4 mV -10 V to 10 V DC :5.7 mV
Overall accuracy	23 ±2°C: ±0.2% (full scale) 0 - 55°C: ±0.5% (full scale)
Conversion speed	1 ms × (number of inputs)
Scaling	Upper and lower limit values can be set to any value between -20,000 to 20,000.
Filter	Channels can be enabled or disabled individually.*3
Current consumption	210 mA (5 V DC)
External connection	18-point terminal block, M3.5 screw
External dimensions	28.9 (W) × 100 (H) × 83.2 (D) mm *4
Weight	200 g

*1: Selectable for each channel using software. The default setting is -10 V to 10 V DC.

*2: 2 MW for channels in which the input terminal IN□- is not connected to the AG terminal.

*3: The actual time constant value varies according to the number of unskipped channels and other settings.

*4: Excluding protrusions (see external dimensions for details).

Components and Functions

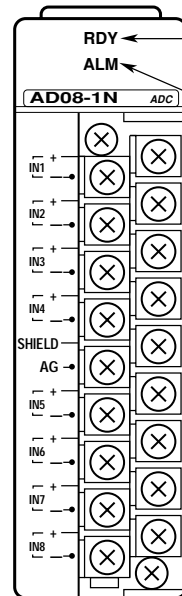

RDY indicator
Lit when the internal circuit is functioning normally.

ALM indicator
Lit when calibration data* is lost. In such a case, the F3AD08-1N will carry out A/D conversion but not satisfy the accuracy requirements.

Terminal block
18-point detachable terminal block. The terminal screws are M3.5 screws with square captive washers.

* : Calibration data is stored in the module to achieve the intended accuracy. The user cannot change this data.

Internal Circuit Diagram

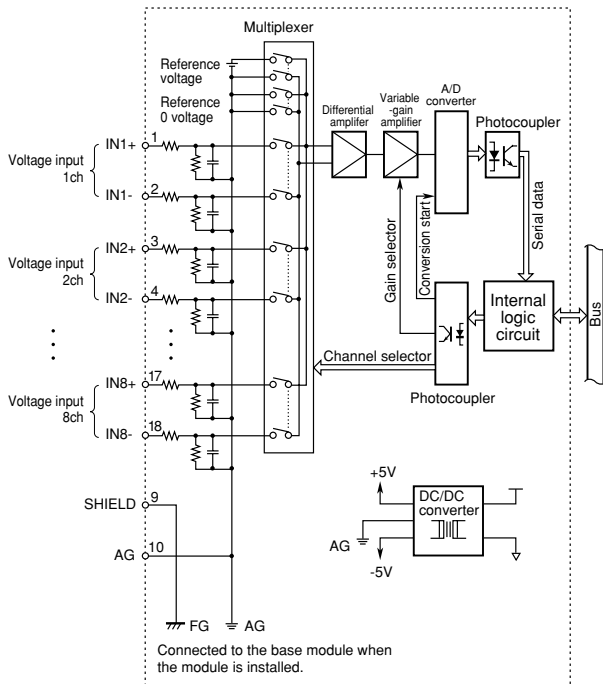

Operating Environment

There is no restriction on the type of CPU modules that can be used with this module.

Model and Suffix Codes

Model	Suffix Code	Style Code	Option Code	Description
F3AD08	-1N	0 V to 5 V, 1 V to 5 V, or -10 V to 10 V DC, 8 inputs, differential input signal, 12-bit A/D

External Dimensions

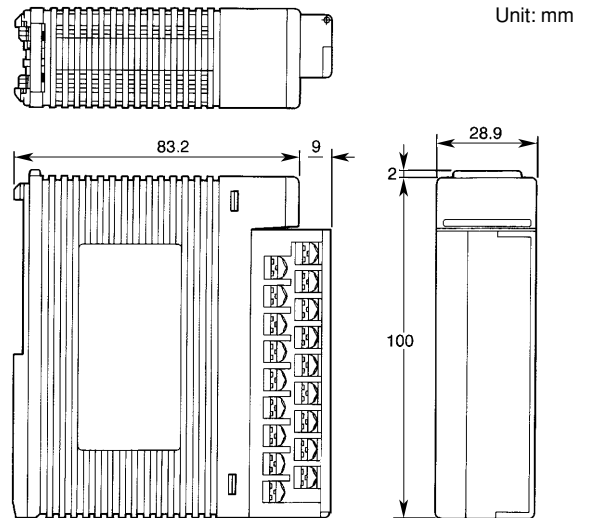

External Connection Diagram

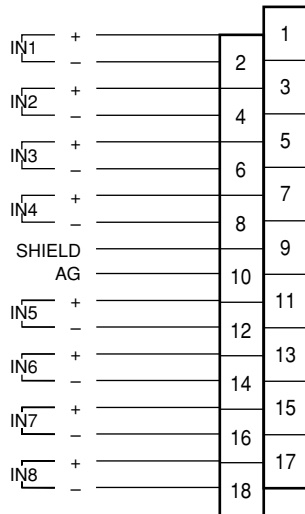

- Shielded terminals are connected to the frame ground of the power supply module via the base module.
- The AG terminal is grounded to the analog ground in the base module.

General Specifications

F3DA02-0N Analog Output Module

FA-M3



General

The F3DA02-0N is a digital-to-analog conversion output module for the FA-M3.

- The output signal range can be selected from -10 V to 10 V DC and 4 mA to 20 mA DC.
- A single module can accommodate two output points.
- The state of each D/A converter output is de-multiplexed and held to two points.
- The output terminals are isolated from the internal circuit by photocouplers.
- The conversion speed (output update period) is as fast as 2 ms/point (fixed).
- An easy-to-use scaling feature is provided.

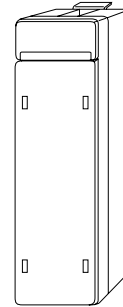

Specifications

Item	Specification
Number of outputs	2
Output signal range*1	-10 V to 10 V DC (-11.0 V to 11.0 V DC) 4 mA to 20 mA DC (1.25 mA to 21.0 mA DC) (one line common, floating type)
Insulation method	Between output terminals and internal circuit: Photocoupler insulation Between output terminals: Non-insulation minus common
Withstand voltage	500 V DC for 1 minute
Allowable load resistance	Voltage output : 5 K Ω min. Current output : 600 Ω max.
Resolution (12-bit A/D)	Voltage output: 5.7 mV Current output: 5.7 μ A
Overall accuracy	23 \pm 2 $^{\circ}$ C: \pm 0.2% (full scale) 0 - 55 $^{\circ}$ C: \pm 0.5% (full scale)
Conversion speed	2 ms (fixed)
Current consumption	100 mA (5 V DC)
External power supply*2	Absolute maximum rating : 30 V DC Operating range : 24 V DC \pm 10%, 150 mA
Scaling	Upper and lower limit values can be set to any value between -20,000 to 20,000.
External connection	10-point terminal block, M3.5 screw
External dimensions	28.9 (W) \times 100 (H) \times 83.2 (D) mm ³
Weight	155 g

- *1: Selectable for each channel by selecting the terminal.
 *2: An external power supply is required to use this module.
 *3: Excluding protrusions (see external dimensions for details).

Components and Functions

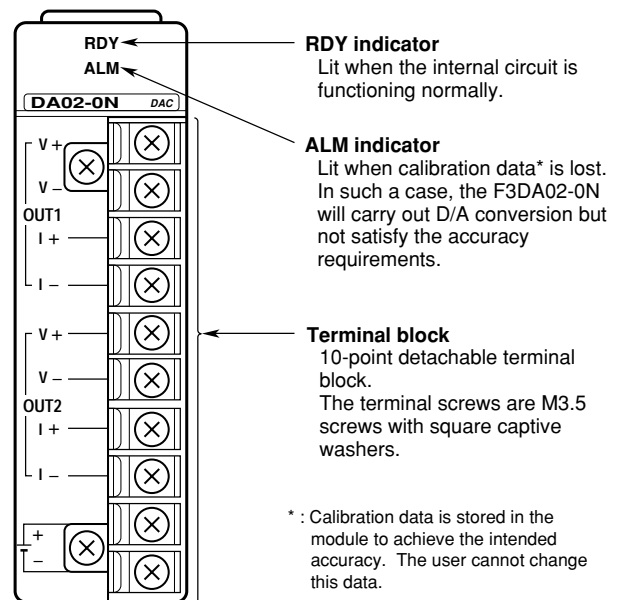

Internal Circuit Diagram

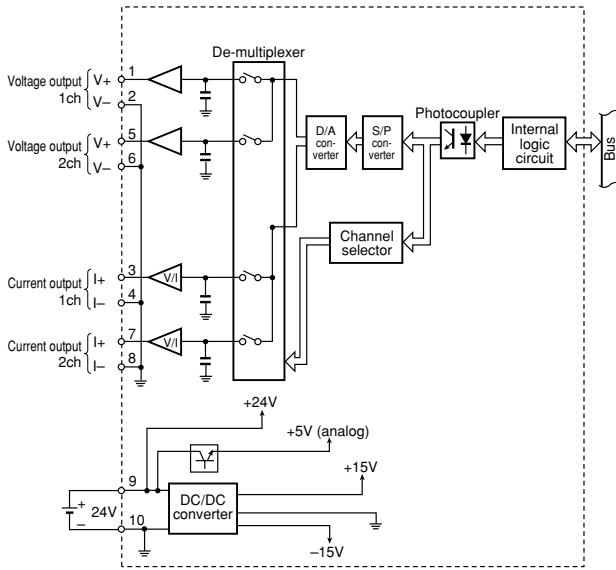

External Connection Diagram

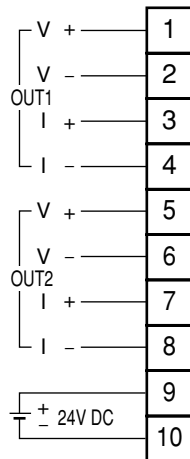

Operating Environment

There is no restriction on the type of CPU modules that can be used with this module.

Model and Suffix Codes

Model	Suffix Code	Style Code	Option Code	Description
F3DA02	-0N	-10 V to 10 V or 4 mA to 20 mA DC, 2 outputs, 12-bit D/A

External Dimensions

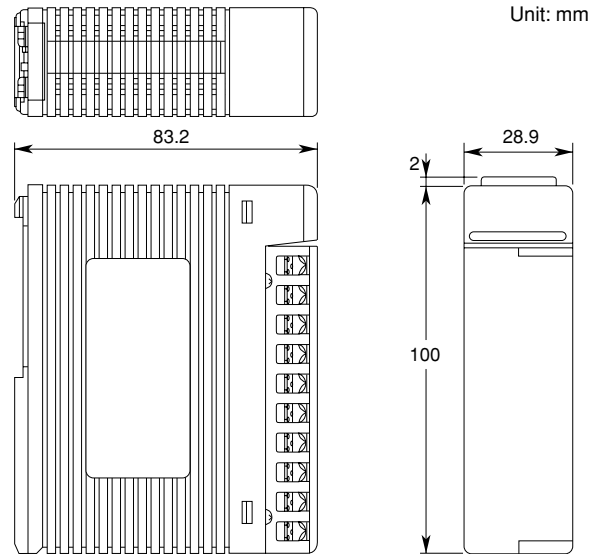

General Specifications

F3DA04-1N Analog Output Module

FA-M3



General

The F3DA04-1N is a digital-to-analog conversion output module for the FA-M3.

- The output signal range can be selected from -10 V to 10 V DC and 4 mA to 20 mA DC.
- A single module can accommodate four output points.
- The state of each D/A converter output is de-multiplexed and held to four points.
- The output terminals are isolated from the internal circuit by photocouplers.
- The conversion speed (output update period) is as fast as 4 ms/point (fixed).
- An easy-to-use scaling feature is provided.
- The user can select either a hold output or a preset output as a CPU fail output for each channel.

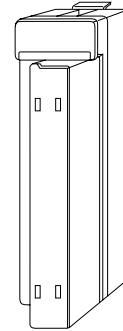

Specifications

Item	Specification
Number of outputs	4
Output signal range*1	-10 V to 10 V DC (-11.0 V to 11.0 V DC) 4 mA to 20 mA DC (1.25 mA to 21.0 mA DC) (one line common, floating type)
Insulation method	Between output terminals and internal circuit: Photocoupler insulation Between output terminals: Non-insulation minus common
Withstand voltage	500 V DC for 1 minute
Allowable load resistance	Voltage output : 5 K Ω min. Current output : 600 Ω max.
Resolution (12-bit A/D)	Voltage output: 5.7 mV Current output: 5.7 μ A
Overall accuracy	23 \pm 2 $^{\circ}$ C: \pm 0.2% (full scale) 0 - 55 $^{\circ}$ C: \pm 0.5% (full scale)
Conversion speed	4 ms (fixed)
Current consumption	100 mA (5 V DC)
External power supply*2	Absolute maximum rating : 30 V DC Operating range : 24 V DC \pm 10%, 180 mA
Scaling	Upper and lower limit values can be set to any value between -20,000 to 20,000.
CPU fail-time operation	Two output modes are supported: 1 Hold output: The fail-time value is retained. 2 Preset output: A default value is generated.
External connection	18-point terminal block, M3.5 screw
External dimensions	28.9 (W) \times 100 (H) \times 83.2 (D) mm*3
Weight	200 g

*1: Selectable for each channel by selecting the terminal.

*2: An external power supply is required to use this module.

*3: Excluding protrusions (see external dimensions for details).

Components and Functions

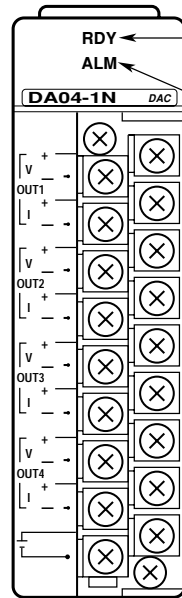

RDY indicator
Lit when the internal circuit is functioning normally.

ALM indicator
Lit when calibration data* is lost. In such a case, the F3DA04-1N will carry out D/A conversion but not satisfy the accuracy requirements.

Terminal block
18-point detachable terminal block. The terminal screws are M3.5 screws with square captive washers.

* : Calibration data is stored in the module to achieve the intended accuracy. The user cannot change this data.

Internal Circuit Diagram

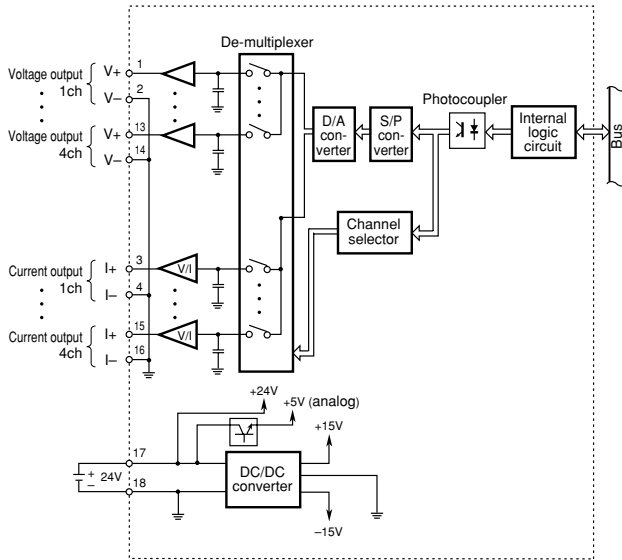

External Connection Diagram

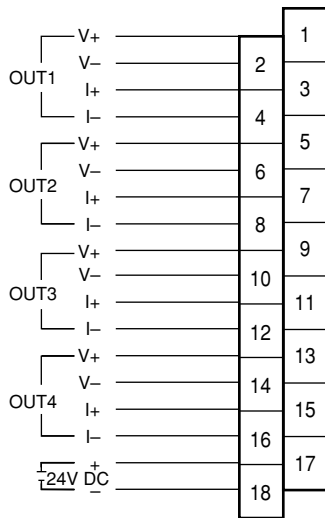

Operating Environment

There is no restriction on the type of CPU modules that can be used with this module.

Model and Suffix Codes

Model	Suffix Code	Style Code	Option Code	Description
F3DA04	-1N	-10 V to 10 V or 4 mA to 20 mA DC, 4 outputs, 12-bit D/A

External Dimensions

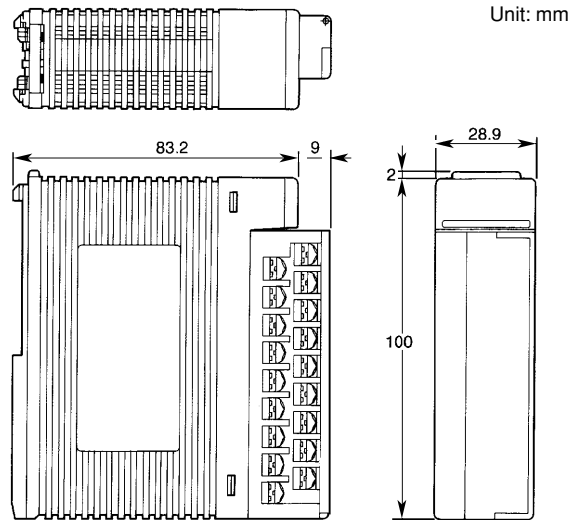

General Specifications

F3DA08-5N Analog Output Module

FA-M3



General

The F3DA08-5N is a digital-to-analog conversion output module for the FA-M3.

- The output signal range is -10 V to 10 V DC.
- A single module can accommodate eight output points.
- The state of each D/A converter output is de-multiplexed and held to eight points.
- The output terminals are isolated from the internal circuit by photocouplers.
- The conversion speed (output update period) is as fast as 4 ms/point (fixed).
- An easy-to-use scaling feature is provided.
- The user can select either a hold output or a preset output as a CPU fail output for each channel.

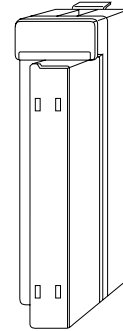

Specifications

Item	Specification
Number of outputs	8
Output signal range*1	-10 V to 10 V DC (-11.0 V to 11.0 V DC) (one line common, floating type)
Insulation method	Between output terminals and internal circuit: Photocoupler insulation Between output terminals: Non-insulation minus common
Withstand voltage	500 V DC for 1 minute
Allowable load resistance	Voltage output:5 KΩ min.
Resolution (12-bit A/D)	Voltage output:5.7 mV
Overall accuracy	23 ±2°C: ±0.2% (full scale) 0 - 55°C: ±0.5% (full scale)
Conversion speed	4 ms (fixed)
Current consumption	100 mA (5 V DC)
External power supply*2	Absolute maximum rating : 30 V DC Operating range:24 V DC ±10%, 180 mA
Scaling	Upper and lower limit values can be set to any value between -20,000 to 20,000.
CPU fail-time operation	Two output modes are supported: 1. Hold output: The fail-time value is retained. 2. Preset output: A default value is generated.
External connection	18-point terminal block, M3.5 screw
External dimensions	28.9 (W) × 100 (H) × 83.2 (D) mm ³
Weight	200 g

- *1: Selectable for each channel by selecting the terminal.
 *2: An external power supply is required to use this module.
 *3: Excluding protrusions (see external dimensions for details).

Components and Functions

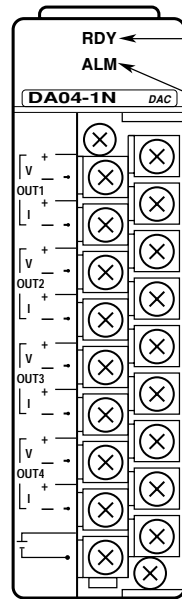

RDY indicator
Lit when the internal circuit is functioning normally.

ALM indicator
Lit when calibration data* is lost. In such a case, the F3DA08-5N will carry out D/A conversion but not satisfy the accuracy requirements.

Terminal block
18-point detachable terminal block. The terminal screws are M3.5 screws with square captive washers.

*: Calibration data is stored in the module to achieve the intended accuracy. The user cannot change this data.

Internal Circuit Diagram

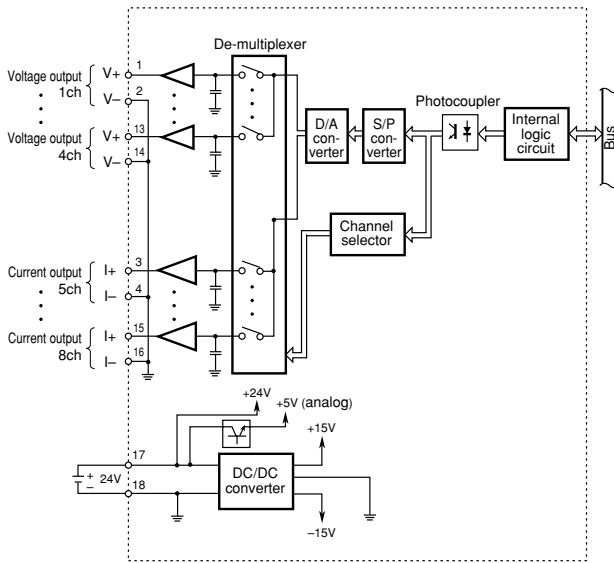

External Connection Diagram

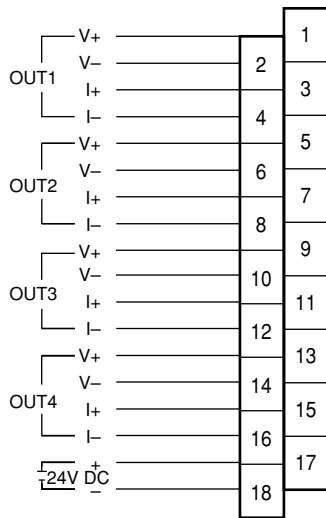

Operating Environment

There is no restriction on the type of CPU modules that can be used with this module.

Model and Suffix Codes

Model	Suffix Code	Style Code	Option Code	Description
F3DA08	-5N	-10 V to 10 V DC, 8 outputs, 12-bit D/A

External Dimensions

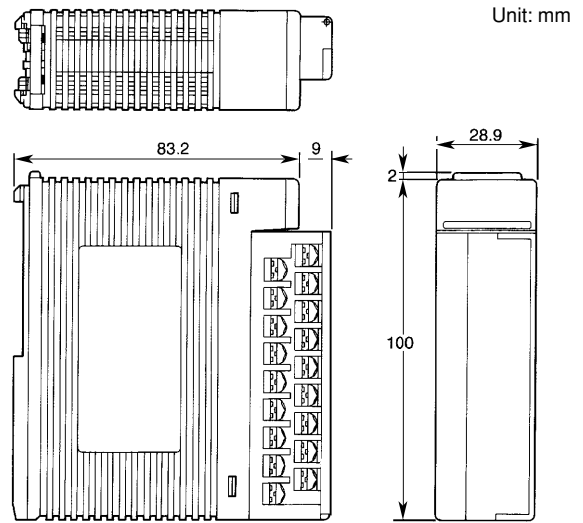

General Specifications

F3CT04-0N and F3CT04-1N Temperature Control and Monitoring Modules (Thermocouple and mV Inputs)

FA-M3



General

The F3CT04-0N and F3CT04-1N are temperature control and monitoring modules for the FA-M3.

- A single module can control or monitor four thermocouple or mV inputs.
- It adopts a multi-range input system so that the user can easily set a range (for all four channels) with a rotary switch.
- It adopts a universal control output system so that the user can select either time-proportional PID output (open-collector or voltage pulse output) or continuous PID output (4-20 mA) for each channel. The continuous PID output (4-20 mA) is supported only by the F3CT04-1N.
- It can also serve as a heating-cooling controller. Cooling requires a different output module.
- When used in combination with a ladder or BASIC application program, the module offers multichannel cascade control.
- A loopback feature facilitates system debugging.
- It is equipped, as standard, with not only auto-tuning but also the "super" feature that makes use of fuzzy logic to suppress output overshooting.
- PID constants, settings, which are required for process control, are maintained in the module, so there is no need to reset the parameters each time the module operates.

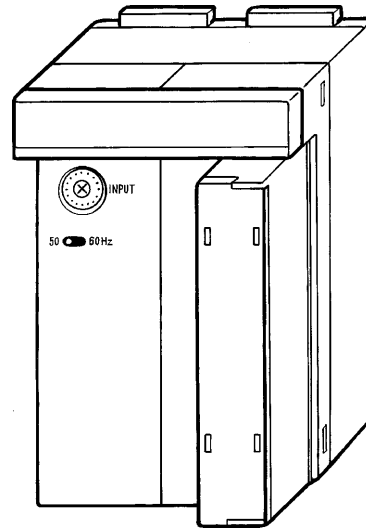

Components and Functions

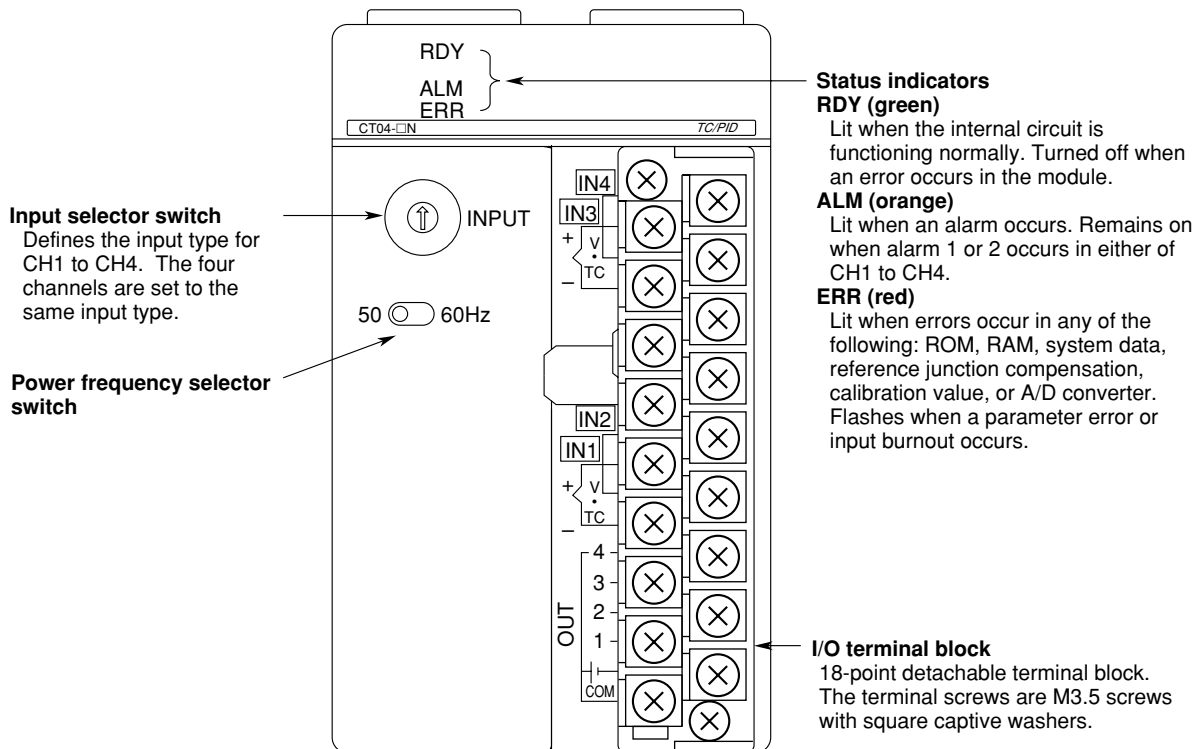

■ Electrical and Mechanical Data

Item		Specification		
		F3CT04-0N	F3CT04-1N	
Number of loops		4		
Insulation method	Between input terminals and internal circuit	Photocoupler insulation, withstand voltage: 1000 V AC		
	Between output terminals and internal circuit	Photocoupler insulation, withstand voltage: 1500 V AC		
	Between output terminals	Non-insulation		
Input Block	Input type	Thermocouple (14 types) and DC voltage (2 types); same range selected for all 4 channels. See the table on the next page for input ranges and accuracy.		
	Insulation resistance between input terminals	20 MΩ min.		
	Input sampling period	500 ms (4 channels), 250 ms (2 channels)* or 125 ms (1 channel)* *: The maximum number of channels that is available in a single module is limited as indicated in parentheses for periods of 250 ms and 125 ms.		
	Thermocoupler input	Input resistance	1 MΩ min.	
		Allowable signal resistance	250 Ω max.	
		Reference junction compensation	Reference junction temperature 0 - 10°C ±1.5°C	Reference junction temperature 0 - 55°C ±2°C
Reference junction temperature 10 - 35°C ±1°C				
Reference junction temperature 35 - 55°C ±1.5°C				
Burnout detection	Provided (upscale operation only; this function cannot be disabled.)			
Control block	Control functions	PID control, heating-cooling control* ¹ , settings output* ² * ¹ : An analog output module or contract output module is also used for cooling output. * ² : The control target value is generated as an operation output.		
	Control period	Continuous PID output: Same as the input sampling period. The control period for heating-cooling and settings output is fixed at 500 ms. Time-proportional PID output: Same as cycle time.		
	Loopback	Provided		
	Auto tuning ^(Note 2)	The "limit cycle method" is used.		
	Overshoot suppression ^(Note 3)	"Super" which makes use of "fuzzy logic." Enabled or disabled can be set for each channel.		
	Tracking	Output tracking: Automatic-to-manual switching enables output to be transfer bumplessly. Preset value tracking: There is no sudden change in the preset value at power-on, or when the preset value is exchanged between preset values 1 and 2. Enabled or disabled can be set.		
Output Block	Output type (see the table on the next page for output specifications.)	Time-proportional PID (open-collector)	Provided (ON/OFF control and direct/reverse action supported)	
		Time-proportional PID (voltage pulse)	Provided (ON/OFF control and direct/reverse action supported)	
		Continuous PID (4 - 20 mA)	Not provided	Provided (ON/OFF control and direct/reverse action supported)
Noise rejection ratios		Normal mode: 40 dB (50/60 Hz) Common mode: 120 dB (50/60 Hz)		
External power supply ^(Note 1)	Open-collector output	24 V DC ±10%, 100 mA		
	Voltage pulse output	24 V DC ±10%, 200 mA		
	4 - 20 mA output	—	24 V DC ±10%, 200 mA	
Alarm		2 points for each channel, selectable from 12 types of alarms including measured value alarm, deviation alarm, and deviation range alarm.		
Effect of changes in ambient temperature		Input stability: ±1 μV/°C or ±0.01% /°C, whichever is greater Output stability: ±0.05% /°C of output span or less* *: The output stability applies to the F3CT04-1N in the 4 - 20 mA output mode.		
Warmup time		30 minutes min.		
External connection		18-point terminal block, M3.5 screw		
External dimensions		58 (W) × 100 (H) × 83.2 (D) mm, excluding protrusions (see external dimensions for details.)		
Weight		250 g		

Note1: A 24 V DC external power supply is required to use this module. When the module output terminal is not used, as in temperature input applications, no external power is required.

Note2: The auto tuning is disabled when heating-cooling control is used.

Note3: Not available for heating-cooling and ON/OFF control.

■ Input Range and Accuracy

Input Type	Instrument Range	Range Code	Accuracy
K	-200°C to 1300°C *1	0	±0.3%±1 digit
K	-199.9°C to 999.9°C *1	1	
K	-199.9°C to 500.0°C *1	2	
J	-199.9°C to 800.0°C *1	3	
T	-199.9°C to 400.0°C *2	4	
B	0°C to 1800°C *3	5	
S	0°C to 1700°C	6	
R	0°C to 1700°C	7	
N	0°C to 1300°C	8	
W	0°C to 2300°C	9	
E	-199.9°C to 800.0°C	A	
L	-199.9°C to 800.0°C	B	
U	-199.9°C to 400.0°C	C	
Platinel 2	0°C to 1390°C	D	
mV	0°C to 10 mV	E	
	0°C to 100 mV	F	

*1: Accuracy is ±0.5 % ±1 digit for the range between -199.9°C and -100.0°C.

*2: Accuracy is ±0.5 % ±1 digit for the range between -199.9°C and 0.0°C.

*3: Accuracy is ±5 % ±1 digit for the range between 0°C and 400°C.

■ Output Types

Control Output Type	Specification	Resolution
Time-proportional PID (open-collector)	Rated load voltage : 24 V DC Maximum load current : 0.1 A/point, 0.4 A/common Cycle time : 1 - 240 s External power supply : 24 V DC ±10%, 100 mA	10 ms or 0.05%, whichever is greater
Time-proportional PID (voltage pulse)	ON voltage : Approx. 6 V DC min. (load resistance of 600 Ω or greater) OFF voltage : 0.5 V DC max. Cycle time : 1 - 240 s External power supply : 24 V DC ±10%, 200 mA	
Continuous PID (4 - 20 mA)*	Load resistance : 600 Ω max. Accuracy : ±1.0% for output span Output range : -5 to 105% for output span Output update period : 500 ms, 250 ms, or 125 ms (same as input sampling period) External power supply : 24 V DC ± 10%, 200 mA	0.05%

*: For the F3CT04-1N only.

External Connection Diagram

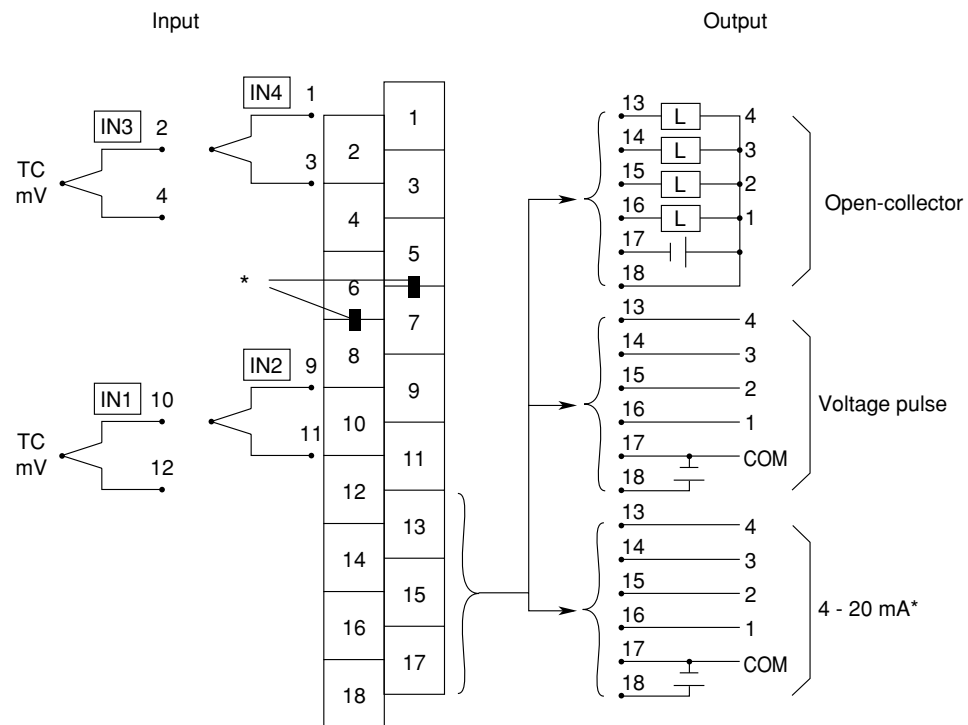

Note: The reference junction compensator (RJC) is attached at the factory.

*: For the F3CT04-1N only.

■ Function Block Diagram

The diagram shown below is a function block diagram for one channel of the module. Each of the four channels has the same functions as shown in this block diagram.

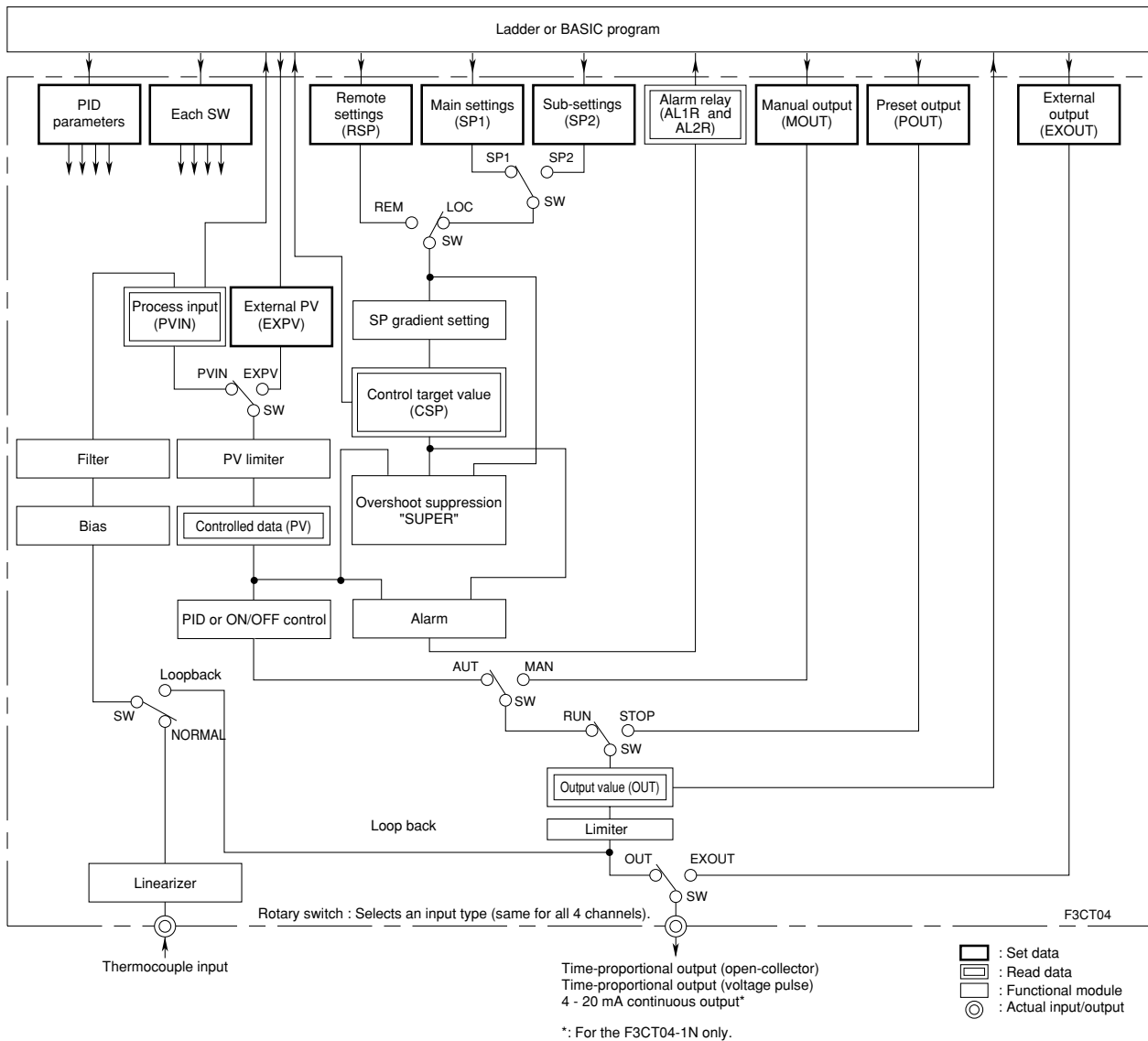

Operating Environment

There is no restriction on the type of CPU modules that can be used with these modules.

Model and Suffix Codes

Model	Suffix Code	Style Code	Option Code	Description
F3CT04	-0N	Thermocouple input, time-proportional PID output, 4 loops
F3CT04	-1N	Thermocouple inputs, time-proportional PID output, continuous PID output, 4 loops

External Dimensions

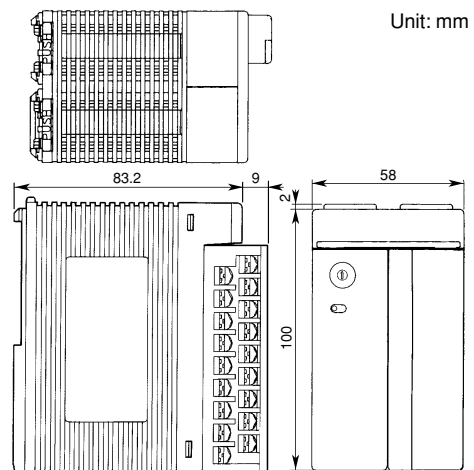

General Specifications

F3CR04-0N and F3CR04-1N Temperature Control and Monitoring Modules (RTD Input)

FA-M3



General

The F3CR04-0N and F3CR04-1N are temperature control and monitoring modules for the FA-M3.

- A single module can control or monitor four RTD inputs.
- It adopts a multi-range input system so that the user can easily set a range (for all four channels) with a rotary switch.
- It adopts a universal control output system so that the user can select either time-proportional PID output (open-collector or voltage pulse) or continuous PID output (4-20 mA) for each channel. The continuous PID output (4-20 mA) is only supported by the F3CR04-1N.
- It can also serve as a heating-cooling controller.
- When used in combination with a ladder or BASIC application program, the module offers multichannel cascade control and override control.
- A loopback feature facilitates system debugging.
- It is equipped, as standard, with not only auto-tuning but also the "super" feature that makes use of fuzzy logic to suppress output overshooting.
- PID constants, settings, which are required for process control, are maintained in the module, so there is no need to reset the parameters each time the module operates.

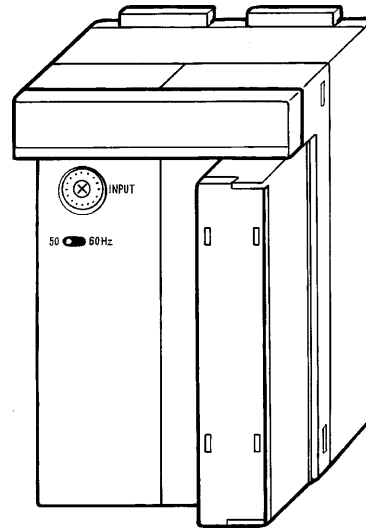

Components and Functions

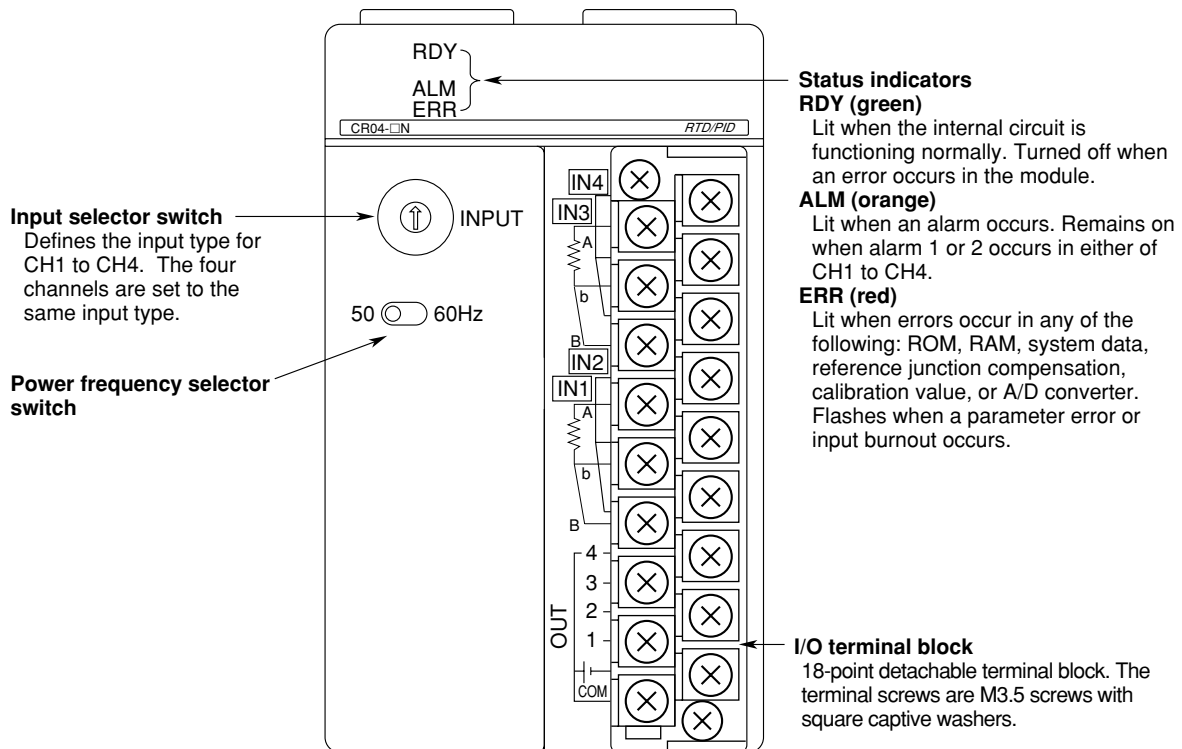

■ Electrical and Mechanical Data

Item		Specification		
		F3CR04-0N	F3CR04-1N	
Number of loops		4		
Insulation method		Between input terminals	Non-insulation	
		Between input terminals and internal circuit	Photocoupler insulation, withstand voltage: 1000 V AC	
		Between output terminals and	Photocoupler insulation, withstand voltage: 1500 V AC	
			Non-insulation	
Input Block	Input type		RTD(2 types); same range selected for all 4 channels. See the table on the next page for input ranges and accuracy.	
	Input sampling period		500 ms (4 channels), 250 ms (2 channels)* or 125 ms (1 channel)* *: The maximum number of channels available in a single module is limited as indicated in parentheses for periods of 250 ms and 125 ms.	
	RTD input	Allowable signal resistance	10 Ω max./line (no fluctuation among the three lines)	
		Burnout detection	Provided (upscale operation only; this function cannot be disabled.)	
Control block		Control functions	PID control, heating-cooling control* ¹ , settings output* ² * ¹ : An analog output module or contact output module is also used for heating-cooling output. * ² : The control target value is generated as an operation output.	
		Control period	Continuous PID output: Same as the input sampling period. The control period for heating-cooling and settings output is fixed at 500 ms. Time-proportional PID output: Same as cycle time.	
		Loopback	Provided	
		Auto tuning ^{Note 2}	The "limit cycle method" is used.	
		Overshoot suppression function ^{Note 3}	"Super" which makes use of "fuzzy logic." Enabled or disabled can be set for each channel.	
		Tracking	Output tracking: Automatic-to-manual switching enables output to be transferred bumplessly. Preset value tracking: There is no sudden change in the preset value at power-on, or when the preset value is exchanged between preset values 1 and 2. Enabled or disabled can be set.	
Output Block	Output type (see the table on the next page for output specifications.)	Time-proportional PID (open-collector)	Provided (ON/OFF control and direct/reverse action supported)	
		Time-proportional PID (voltage pulse)	Provided (ON/OFF control and direct/reverse action supported)	
		Continuous PID (4-20 mA)	Not provided	Provided (ON/OFF control and direct/reverse action supported)
Noise rejection ratios		Normal mode: 40 dB (50/60 Hz) Common mode: 20 dB (50/60 Hz)		
External power supply ^(Note 1)		Open-collector output	24 V DC ±10%, 100 mA	
		Voltage pulse output	24 V DC ±10%, 200 mA	
		4 - 20 mA output	–	24 V DC ±10%, 200 mA
Alarm		2 points for each channel, selectable from 12 types of alarms including measured value alarm, deviation alarm and deviation range alarm.		
Effect of changes in ambient temperature		Input stability: ±1 μV/°C or ±0.01%/°C, whichever is greater Output stability: ±0.05%/°C of output span or less* *: The output stability applies to the F3CR04-1N in the 4-20 mA output mode.		
Warm-up time		30 minutes min.		
External connection		18-point terminal block, M3.5 screw		
External dimensions		58 (W) × 100 (H) × 83.2 (D) mm, excluding protrusions (see external dimensions for details.)		
Weight		250 g		

Note1: A 24 V DC external power supply is required to use this module. When the module output terminal is not used, as in temperature input applications, no external power is required.

Note2: The auto tuning is disabled when heating-cooling control is used.

Note3: Not available for heating-cooling and ON/OFF control.

■ Input Range and Accuracy

Input Type	Instrument Range	Range Code	Accuracy
JPt100	-199.9°C to 500°C	0	±0.3%±1 digit (between -100.0°C and 0.0°C: ±0.5%±1 digit)
	0.0°C to 200.0°C	1	
	0.0°C to 100.0°C	2	
	-100.0°C to 100.0°C	3	
Pt100	-199.9°C to 640°C	4	
	-199.9°C to 500°C	5	
	0.0°C to 200.0°C	6	
	0.0°C to 100.0°C	7	
	-100.0°C to 100.0°C	8	

■ Output Type

Control Output Type	Specification	Resolution
Time-proportional PID (open-collector)	Rated load voltage : 24 V DC Maximum load current : 0.1 A/point, 0.4 A/common Cycle time : 1 to 240 s External power supply : 24 V DC ±10%, 100 mA	10 ms or 0.05%, whichever is greater
Time-proportional PID (voltage pulse)	ON voltage : Approx. 6 V DC min. (load resistance of 600 Ω or greater) OFF voltage : 0.5 V DC max. Cycle time : 1 - 240 s External power supply : 24 V DC ±10%, 200 mA	
Continuous PID (4 to 20 mA)*	Load resistance : 600 Ω max. Accuracy : ±1.0% for output span Output range : -5 to 105% for output span Output update period : 500 ms, 250 ms, or 125 ms (same as input sampling period) External power supply : 24 V DC ± 10%, 200 mA	0.05%

*: Available only in F3CR04-1N.

External Connection Diagram

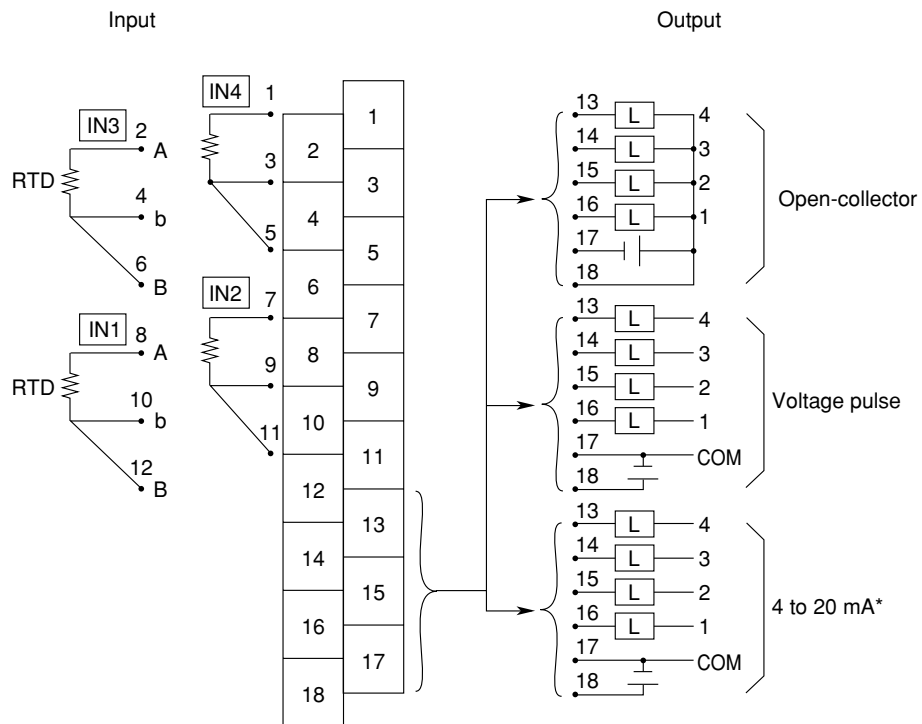

*: For the F3CR04-1N only.

■ Function Block Diagram

The diagram shown below is a function block diagram for one channel of the module. Each of the four channels has the same functions as shown in this block diagram.

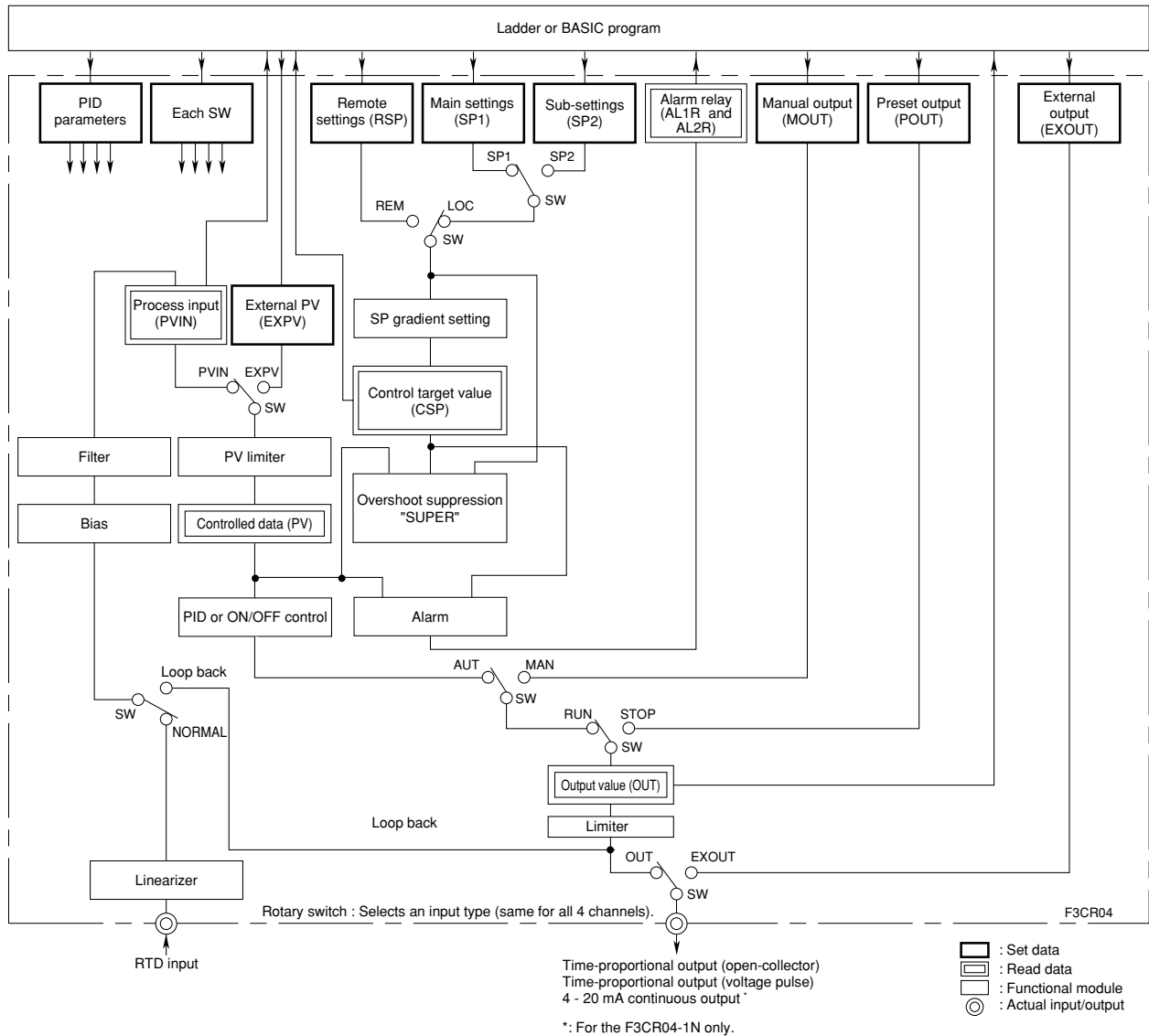

Operating Environment

There is no restriction on the type of CPU modules that can be used with these modules.

Model and Suffix Codes

Model	Suffix Code	Style Code	Option Code	Discription
F3CR04	-0N	RTD input, time-proportional PID output, 4 loops
F3CR04	-1N	RTD input, time-proportional PID output, continuous PID output, 4 loops

External Dimensions

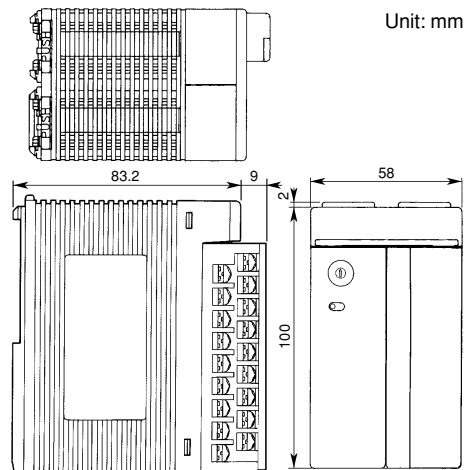

General Specifications

F3CV04-1N PID Control Module (DC V Input)

FA-M3



General

The F3CV04-1N is a PID control module for the FA-M3.

- A single module can control or monitor four DC voltage inputs.
- It adopts a multi-range input system so that the user can easily set a range (for all four channels) with a rotary switch.
- It adopts a universal control output system so that the user can select either time-proportional PID output (open-collector or voltage pulse) or continuous PID output (4-20 mA) for each channel.
- It can also serve as a heating-cooling controller.
- When used in combination with a ladder or BASIC application program, the module offers multichannel cascade control.
- A loopback feature facilitates system debugging.
- It is equipped, as standard, with not only auto-tuning but also the "super" feature that makes use of fuzzy logic to suppress output overshooting.
- PID constants, settings, which are required for process control, are maintained in the module, so there is no need to reset the parameters each time the module operates.

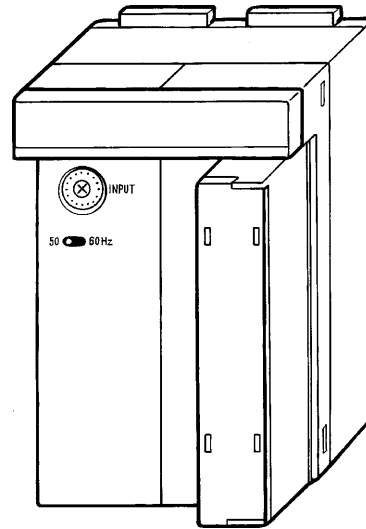

Components and Functions

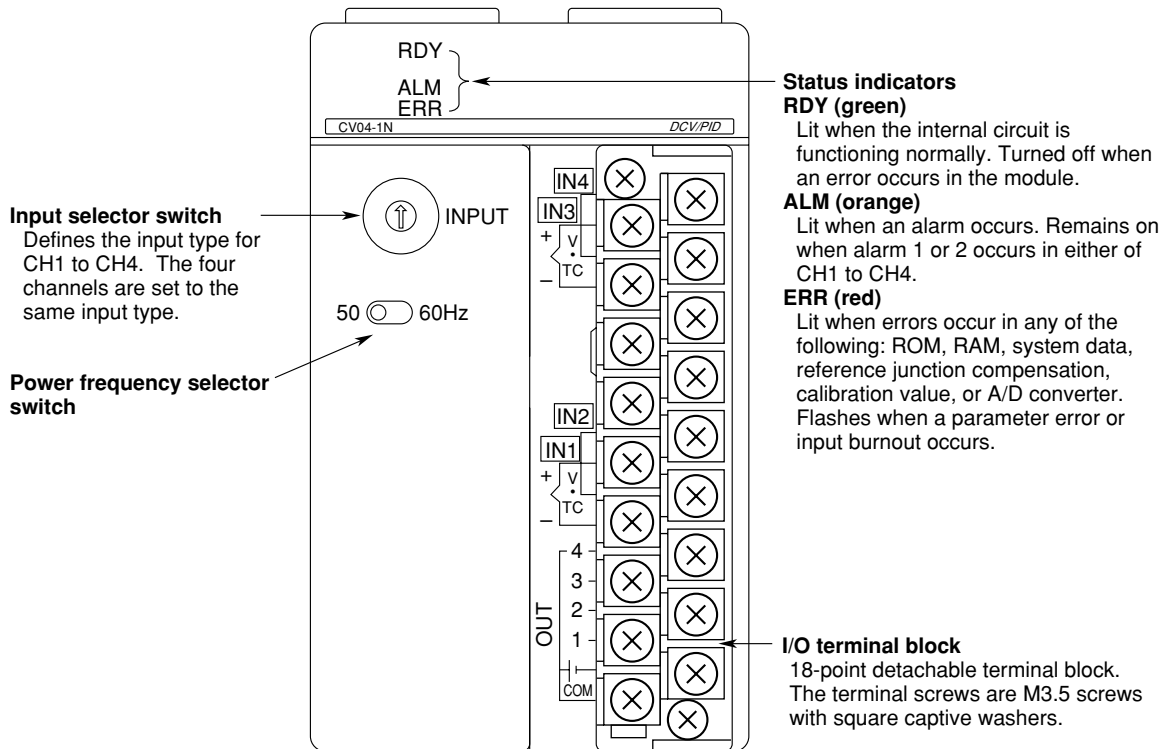

■ Electrical and Mechanical Data

Item		Specification	
Number of loops		4	
Insulation method	Between input terminals and internal circuit	Photocoupler insulation, withstand voltage: 1000 V AC	
	Between output terminals and	Photocoupler insulation, withstand voltage: 1500 V AC	
		Non-insulation	
Input Block	Input type	DC voltage (5 types); same range selected for the 4 channels. See the table on the next page for input ranges and accuracy.	
	Insulation resistance between input terminals	20 MΩ min.	
	Input sampling period	500 ms (4 channels), 250 ms (2 channels)* or 125 ms (1 channel)* *: The maximum number of channels available in a single module is limited as indicated in parentheses for periods of 250 ms and 125 ms.	
	DC voltage input	Input resistance	1MΩ min.
Allowable signal resistance		2 KΩ max. (approx. - 0.1% reading error occurs for each 1 kΩ.)	
Control block	Control functions	PID control, heating-cooling control* ¹ , settings output* ² * ¹ An analog output module or contract output module is also used for cooling output. * ² The control target value is generated as an operation output.	
	Control period	Continuous PID output: Same as the input sampling period. The control period for heating-cooling and settings output is fixed at 500 ms. Time-proportional PID output: Same as cycle time.	
	Loopback	Provided	
	Auto tuning ^{Note 2}	The "limit cycle method" is used.	
	Overshoot suppression ^{Note 3}	"Super" that makes use of "fuzzy logic." Enabled or disabled can be set for each channel.	
	Tracking	Output tracking: Automatic-to-manual switching enables output to be smoothly transferred. Preset value tracking: There is no sudden change in the preset value at power-on, or when the preset value is exchanged between preset values 1 and 2. Enabled or disabled can be set.	
Output Block	Output type (see the table on the next page for output specifications.)	Time-proportional PID (open-collector)	Provided (ON/OFF control and direct/reverse action supported)
		Time-proportional PID (voltage pulse)	Provided (ON/OFF control and direct/reverse action supported)
		Continuous PID (4-20 mA)	Provided (ON/OFF control and direct/reverse action supported)
Noise rejection ratio		Normal mode: 40 dB (50/60 Hz) Common mode: 120 dB (50/60 Hz)	
External power supply ^{Note 1}	Open-collector output	24 V DC ±10%, 100 mA	
	Voltage pulse output	24 V DC ±10%, 200 mA	
	4 - 20 mA output	24 V DC ±10%, 200 mA	
Alarm		2 points for each channel, selectable from 12 types of alarms including measured value alarm, deviation alarm and deviation range alarm.	
Effect of changes in ambient temperature		Input stability: ±1 μV/°C or ±0.01%/°C, whichever is greater Output stability: ±0.05%/°C of output span or less	
Warmup time		30 minutes min.	
External connection		18-point terminal block, M3.5 screw	
External dimensions		58 (W) × 100 (H) × 83.2 (D) mm, excluding protrusions (see external dimensions for details.)	
Weight		250 g	

Note1: A 24 V DC external power supply is required to use this module. When the module output terminal is not used, no external power is required.

Note2: The auto tuning function is disabled when heating-cooling control is used.

Note3: Not available for heating-cooling and ON/OFF control.

■ Input Range and Accuracy

Input Type	Range Code	Accuracy
0 V to 1 V	0	±0.3%±1 digit
-1 V to 1 V	1	±0.2% ±1 digit
0 V to 5 V	2	
1 V to 5 V	3	
0 V to 10 V	4	

-1999 to 9999
Scaling is possible
(modifiable decimal-point position)

■ Output Type

Control Output Type	Specification	Resolution
Time-proportional PID (open-collector)	Rated load voltage : 24 V DC Maximum load current : 0.1 A/point, 0.8 A/common Cycle time : 1 - 120 s External power supply : 24 V DC ±10%, 100 mA	10 ms or 0.05%, whichever is greater
Time-proportional PID (voltage pulse)	ON voltage : Approx. 6 V DC min. (load resistance of 600 Ω or greater) OFF voltage : 0.5 V DC max. Cycle time : 1 - 240 s External power supply : 24 V DC ±10%, 200 mA	
Continuous PID (4 to 20 mA)	Load resistance : 600 Ω max. Accuracy : ±1.0% for output span Output range : -5 to 105% for output span Output update period : 500 ms/250 ms/125 ms (same as input sampling period) External power supply : 24 V DC ± 10%, 200 mA	0.05%

External Connection Diagram

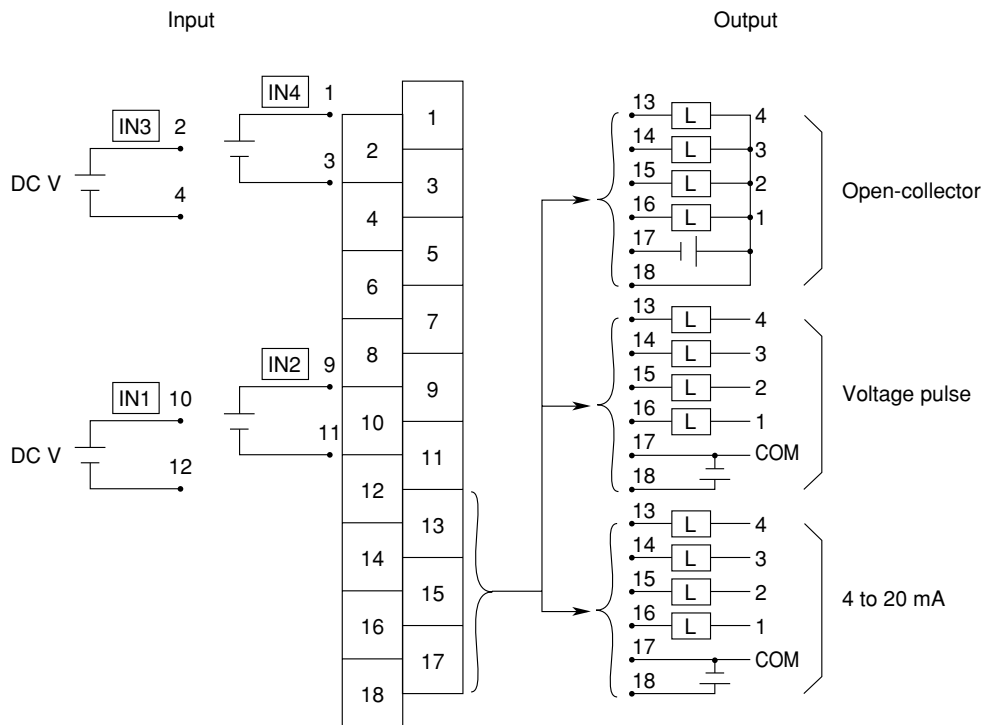

Function Block Diagram

The diagram shown below is a function block diagram for one channel of the module. Each of the four channels has the same functions as shown in this block diagram.

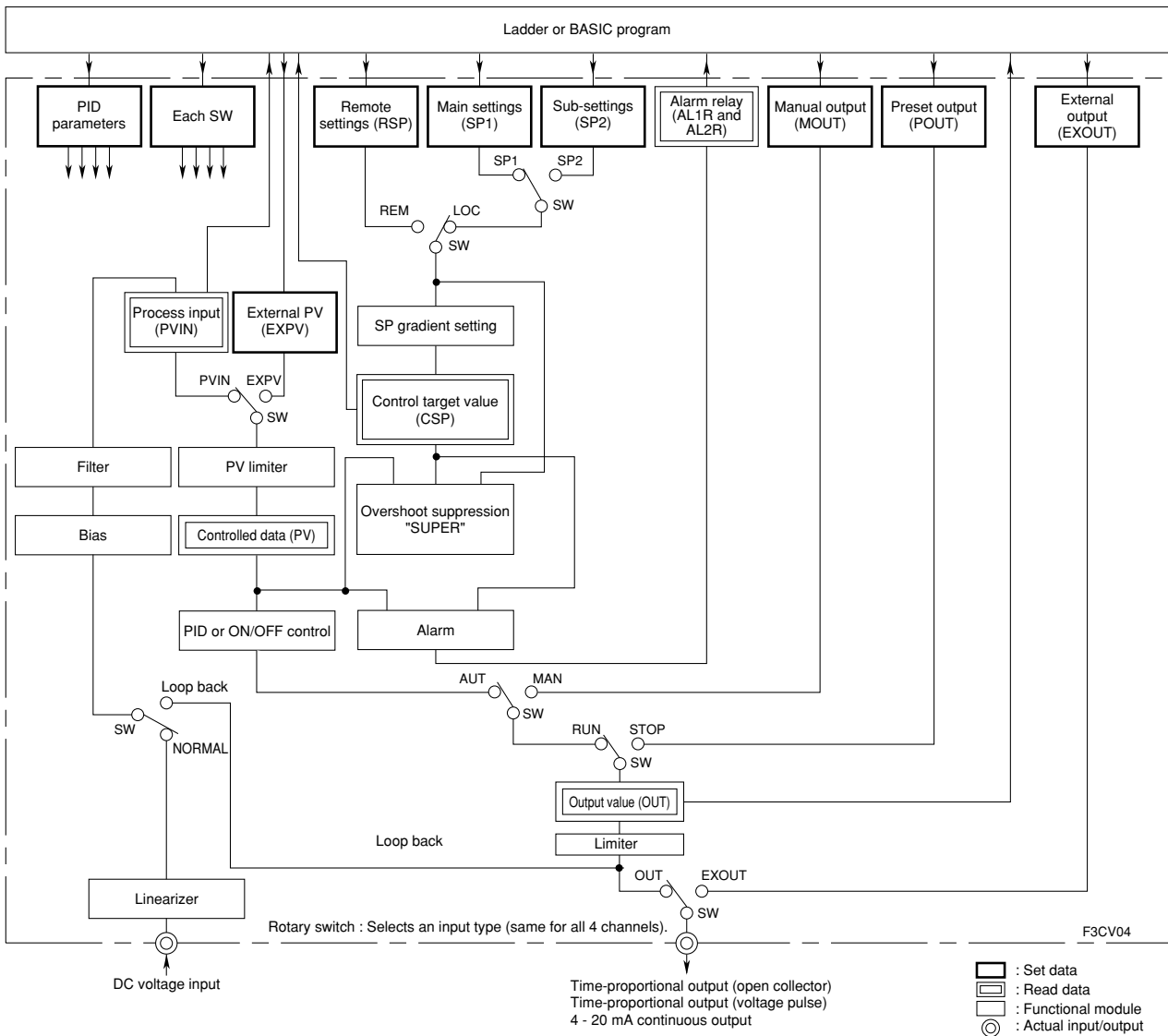

Operating Environment

There is no restriction on the type of CPU modules that can be used with this module.

Model and Suffix Codes

Model	Suffix Code	Style Code	Option Code	Discription
F3CV04	-1N	DC voltage input, 4 loops

External Dimensions

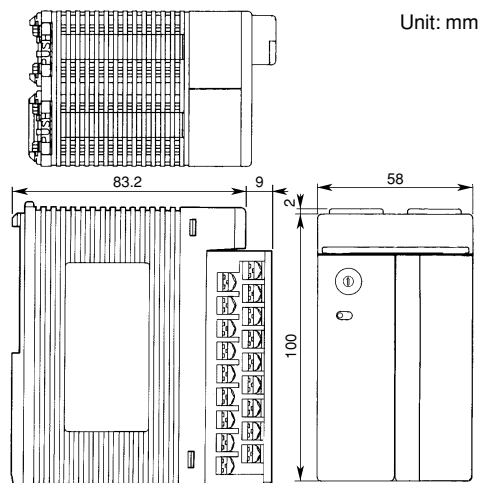

~~~~~Items to Specify When Ordering~~~~~

1. Model and suffix codes